

PIPE DIAMETER, 40 – 125

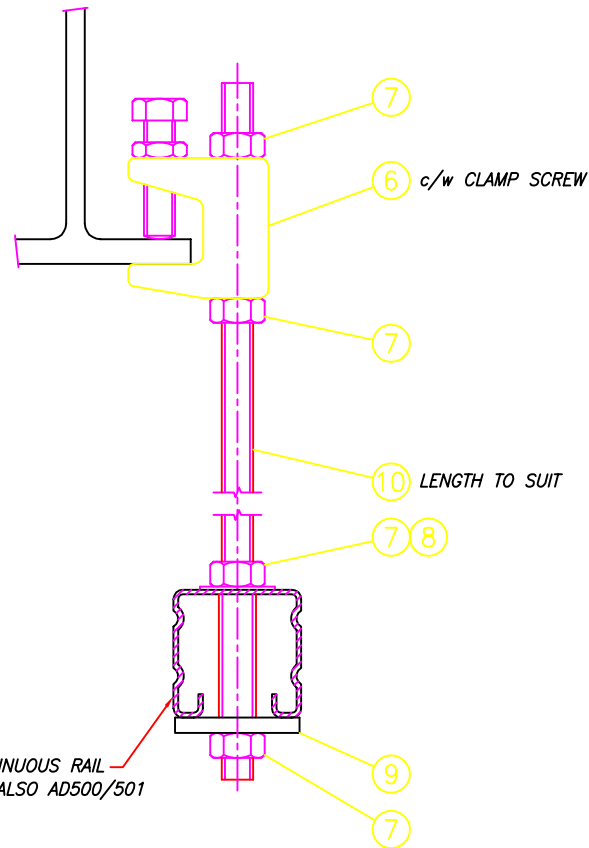

PIPE DIAMETER, 160 – 250

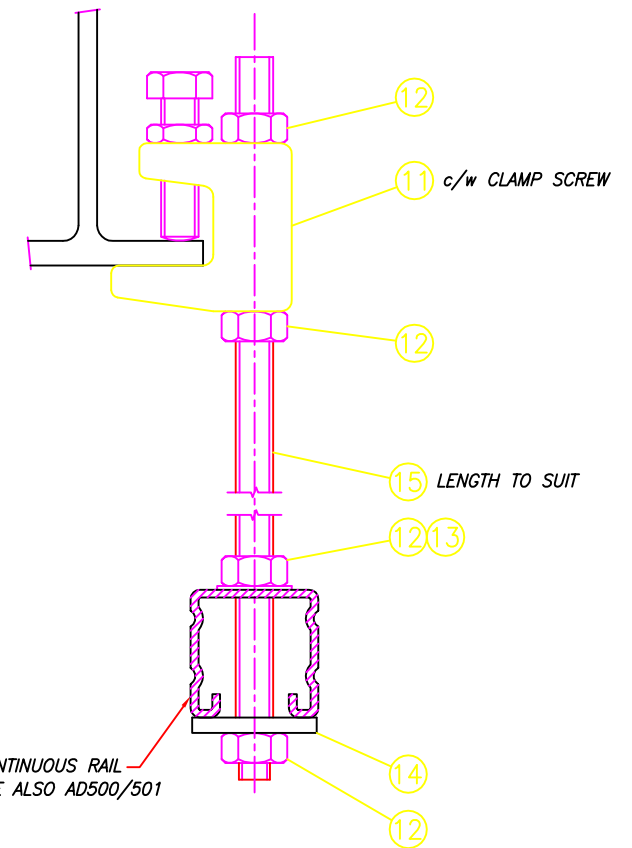

PIPE DIAMETER, 315

THIS DRAWING AND DETAILS CONTAINED WITHIN ARE COPYRIGHT OF HYDROMAX INC. REPRODUCTION OR USE IS PROHIBITED WITHOUT WRITTEN PERMISSION.

Item	Description	Qty	Part No	Item	Description	Qty	Part No
1	Beam Clamp, M8 (BZP)	-	-	11	Beam Clamp, M12 (BZP)	-	-
2	Full nut, M8 (BZP)	-	-	12	Full nut, M12 (BZP)	-	-
3	Repair washer, M8 (BZP)	-	-	13	Plain washer, M12 (BZP)	-	-
4	Square washer, M8 (Galv)	-	-	14	Square washer, M12 (Galv)	-	-
5	Threaded rod, M8 (BZP)	-	-	15	Threaded rod, M12 (BZP)	-	-
6	Beam Clamp, M10 (BZP)	-	-				
7	Full nut, M10 (BZP)	-	-				
8	Repair washer, M10 (BZP)	-	-				
9	Square washer, M10 (Galv)	-	-				
10	Threaded rod, M10 (BZP)	-	-				



Drawn By	Date
W Jackson	06/01/04
Scale	Rev
1:2	00
Drawing No	
AD505	

Drawing Title
TYPICAL FIXING DETAIL; RAIL SUPPORT SYSTEM / BEAM CLAMP